



**Surname** \_\_\_\_\_

**Other Names** \_\_\_\_\_

**Centre Number** \_\_\_\_\_

**Candidate Number** \_\_\_\_\_

**Candidate Signature** \_\_\_\_\_

**GCSE**

**COMBINED SCIENCE: SYNERGY**

**H**

**Higher Tier Paper 2 Life and environmental sciences**

**8465/2H**

**Wednesday 22 May 2019**

**Afternoon**

**Time allowed: 1 hour 45 minutes**

**At the top of the page, write your surname and other names, your centre number, your candidate number and add your signature.**

**[Turn over]**



J U N 1 9 8 4 6 5 2 H 0 1

**BLANK PAGE**



**For this paper you must have:**

- a ruler
- a protractor
- a scientific calculator
- the periodic table (enclosed)
- the Physics Equations Sheet (enclosed).

## **INSTRUCTIONS**

- Use black ink or black ball-point pen.
- Answer ALL questions in the spaces provided. Do not write on blank pages.
- Do all rough work in this book. Cross through any work you do not want to be marked.
- In all calculations, show clearly how you work out your answer.

## **INFORMATION**

- The maximum mark for this paper is 100.
- The marks for questions are shown in brackets.
- You are expected to use a calculator where appropriate.
- You are reminded of the need for good English and clear presentation in your answers.

**DO NOT TURN OVER UNTIL TOLD TO DO SO**



Answer ALL questions in the spaces provided.

0 1

Students in four groups measured their reaction times.

TABLE 1 shows the ranges of reaction times for each group.

TABLE 1

| Group | Range of reaction times in seconds (s) |
|-------|--|
| A     | 0.14 – 0.59                            |
| B     | 0.42 – 1.20                            |
| C     | 0.42 – 0.76                            |
| D     | 0.63 – 1.02                            |



**0 1 . 1** Which group had all their results in the normal range for reaction time? [1 mark]

Tick (✓) ONE box.

**A**

**B**

**C**

**D**

**[Turn over]**



01.2

Describe a method to investigate the effect of caffeine on reaction time. [6 marks]

---

---

---

---

---

---

---

---

---

---

---

---

---

---

---

---

---

---

---

---

---

---

---



---

---

---

---

---

---

---

---

---

---

---

---

---

---

---

---

---

---

---

---

---

---

---

---

---

---

---

---

---

---

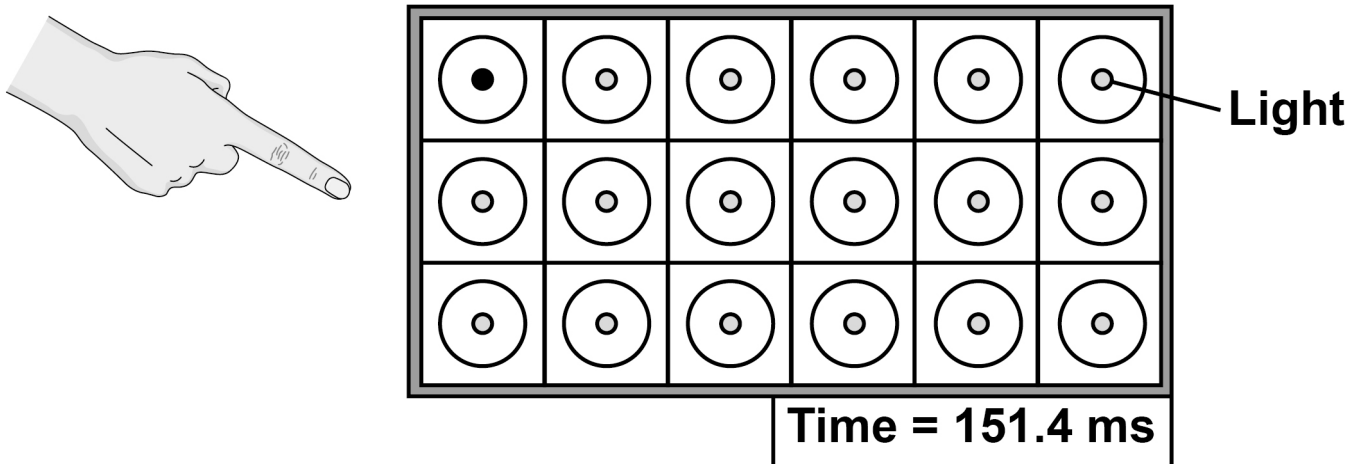
**[Turn over]**



A sports scientist investigated the reaction times of athletes.

FIGURE 1 shows a light box used by the sports scientist.

FIGURE 1



This is the method used.

1. Stand in front of the light box.
2. When a light comes on in a circle, touch the circle as quickly as possible.
3. Record the time taken, as shown on the light box display.
4. Repeat steps 2–3 another four times.



**0 1 . 3** Which word describes cells in the eye that detect the light? [1 mark]

Tick (✓) **ONE** box.

**Coordinators**

**Effectors**

**Receptors**

**Responses**

**[Turn over]**



The scientist compared the reaction time of a male athlete and a female athlete.

01.4

Give TWO factors the scientist should have controlled in the investigation.

Do NOT refer to caffeine in your answer.  
[2 marks]

1

---

---

---

2

---

---

---

**BLANK PAGE**

**[Turn over]**



**TABLE 2** shows the results.

**TABLE 2**

|               | <b>Reaction time in milliseconds (ms)</b> |                       |
|---------------|---|-----------------------|
|               | <b>MALE ATHLETE</b>                       | <b>FEMALE ATHLETE</b> |
| <b>TEST 1</b> | <b>153.6</b>                              | <b>138.2</b>          |
| <b>TEST 2</b> | <b>154.2</b>                              | <b>145.7</b>          |
| <b>TEST 3</b> | <b>150.0</b>                              | <b>149.1</b>          |
| <b>TEST 4</b> | <b>151.4</b>                              | <b>142.9</b>          |
| <b>TEST 5</b> | <b>153.9</b>                              | <b>140.6</b>          |



**0 1 . 5** Which test shows the median reaction time for the female athlete? [1 mark]

Tick (✓) ONE box.

**Test 1**

**Test 2**

**Test 3**

**Test 4**

**Test 5**

**[Turn over]**



## Repeat of TABLE 2

|        | Reaction time in milliseconds (ms) |                |
|--------|------------------------------------|----------------|
|        | MALE ATHLETE                       | FEMALE ATHLETE |
| TEST 1 | 153.6                              | 138.2          |
| TEST 2 | 154.2                              | 145.7          |
| TEST 3 | 150.0                              | 149.1          |
| TEST 4 | 151.4                              | 142.9          |
| TEST 5 | 153.9                              | 140.6          |

**0 1 . 6** Calculate the mean reaction time for the male athlete.

Give your answer to 4 significant figures.  
[2 marks]

---



---



---



---

Mean reaction time = \_\_\_\_\_ ms



- 0 1 . 7** The reaction time for the female athlete in test 1 was 138.2 ms

Give this reaction time in seconds. [1 mark]

---

---

Reaction time = \_\_\_\_\_ s

- 0 1 . 8** Why does repeating the test give more valid results than doing the test only once? [1 mark]

Tick (✓) ONE box.

Anomalies can be identified

Results are reproducible

Errors are prevented

Results are more precise

[Turn over]



**0 1 . 9** The scientist concluded:

**‘Female athletes have shorter reaction times than male athletes.’**

**Suggest why this conclusion may NOT be valid. [1 mark]**

---

---

---

|           |
|-----------|
|           |
| <b>16</b> |



**BLANK PAGE**

**[Turn over]**



0 2

This question is about carbon dioxide emissions.

TABLE 3 shows information about carbon dioxide emissions in the UK.

TABLE 3

| Year | Mass of carbon dioxide in kg $\times 10^5$ |                               |                                |
|------|--|-------------------------------|--------------------------------|
|      | Emitted from electricity production        | Emitted from paper production | Total emitted from all sources |
| 2006 | 1263                                       | 54                            | 6314                           |
| 2009 | 902  | 32                            | 5575                           |
| 2012 | 1258                                       | 29                            | 5567                           |
| 2015 | 768  | 27                            | 5043                           |

0 2 . 1

Suggest TWO reasons why carbon dioxide emissions from paper production decreased from 2006 to 2015. [2 marks]

1

---



---



---



2

---

---

---

**0 2 . 2** Suggest TWO reasons why carbon dioxide emissions from electricity production decreased from 2012 to 2015. [2 marks]

1

---

---

---

2

---

---

---

[Turn over]

**0 2 . 3** Calculate the percentage of the total carbon dioxide emissions in 2006 that was from electricity production. [2 marks]

---

---

---

---

Percentage = \_\_\_\_\_ %

**0 2 . 4** Explain the possible consequences of a future increase in carbon dioxide emissions. [6 marks]

---

---

---

---

---

---



---

---

---

---

---

---

---

---

---

---

---

---

---

---

---

---

---

---

---

---

---

---

---

---

---

**[Turn over]**



---

---

---

---

---

---

---

---

---

---

|    |
|----|
|    |
| 12 |



**0 3**

The gall bladder is part of the digestive system.

The gall bladder produces bile.

Bile is not an enzyme, but bile is involved in the digestion of lipids.

**0 3 . 1**

Lipids are digested to form two products.

Write down the TWO products. [2 marks]

lipids → \_\_\_\_\_ + \_\_\_\_\_

[Turn over]



**A student investigated the effect of human bile on the rate of digestion of full-fat cream.**

**This is the method used.**

- 1. Mix 10 cm<sup>3</sup> of cream and 10 cm<sup>3</sup> of bile solution in a beaker and insert a pH probe.**
- 2. Put 10 cm<sup>3</sup> of lipase solution into a test tube.**
- 3. Place the beaker and the test tube in a water bath at 37 °C**
- 4. After 10 minutes add the lipase solution to the beaker and mix.**
- 5. Leave for 5 minutes and then record the pH of the mixture.**
- 6. Repeat steps 1–5 for different concentrations of bile solution.**

**The starting pH for all the mixtures was pH 10.0**





**03.2** Suggest why the student set the water bath at 37 °C [2 marks]

---

---

---

---

**[Turn over]**



TABLE 4 shows the student's results.

TABLE 4

| Concentration of bile solution in arbitrary units | pH after 5 minutes |
|---|--------------------|
| 0   | 8.2                |
| 1   | 8.1                |
| 2   | 8.0                |
| 3   | 7.8                |
| 4   | 7.5                |
| 5   | 7.2                |

**0 3 . 3** Why does the pH of the mixture decrease from pH 10.0? [1 mark]

---

---

---



**0 3 . 4** Describe the pattern shown in the results in TABLE 4. [1 mark]

---

---

---

**0 3 . 5** Bile emulsifies lipids.

**Emulsification means that large droplets of lipid are changed into many tiny droplets of lipid.**

**Explain why emulsification changes the rate of digestion of lipids. [2 marks]**

---

---

---

---

---

---

---

**[Turn over]**

|   |
|---|
|   |
| 8 |



04

Two plants in a garden were infected with different diseases.

Both plants had areas of discolouration on their leaves.

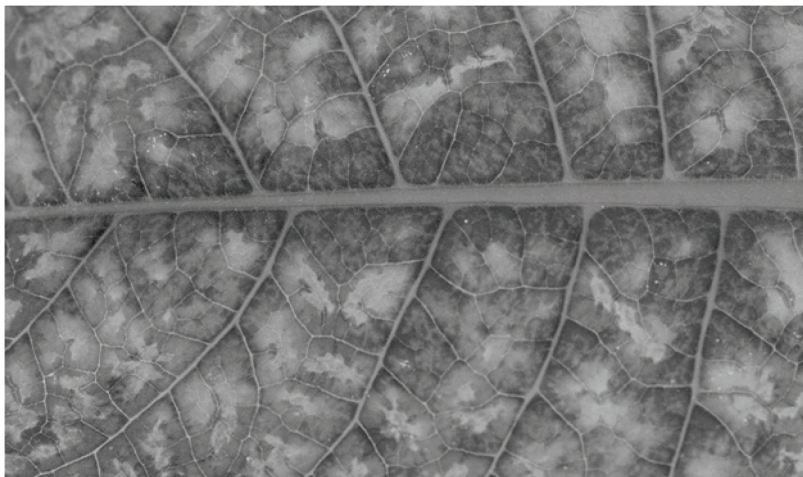
FIGURE 2 shows a leaf from each plant.

FIGURE 2

LEAF FROM ROSE BUSH



LEAF FROM TOMATO PLANT



**0 4 . 1** Identify the infectious disease shown in each plant.

**Explain how you reached this conclusion.  
[4 marks]**

**Rose bush:** \_\_\_\_\_

---

---

---

---

---

---

---

---

**Tomato plant:** \_\_\_\_\_

---

---

---

---

---

---

---

---

**[Turn over]**



Each plant disease shown in FIGURE 2, on page 28, is caused by a different type of microorganism.

Preventing the spread of each disease might involve a different method.

**0 4 . 2** Describe ONE method that would prevent the spread of both types of microorganism.  
[1 mark]

---

---

---

---

**0 4 . 3** Give ONE method that:

- would kill the microorganisms on the rose bush
- but would NOT kill the microorganisms on the tomato plant.

**[1 mark]**

---

---

---

**[Turn over]**



**0 4 . 4** Describe how a microscope in a school laboratory can be used to see the damage to the plant cells. [5 marks]

---

---

---

---

---

---

---

---

---

---

---

---

---

---

---

---

---

---

---

---

---

---

---

---





---

---

---

---

---

---

---

---

---

---

---

[Turn over]

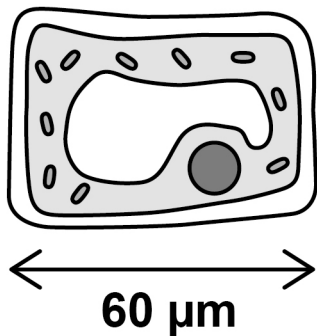


**FIGURE 3** shows diagrams of a plant cell and three types of microorganism.

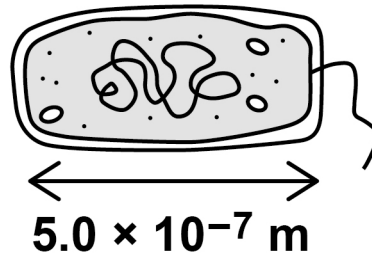
**FIGURE 3**

The diagram is **NOT** drawn to scale.

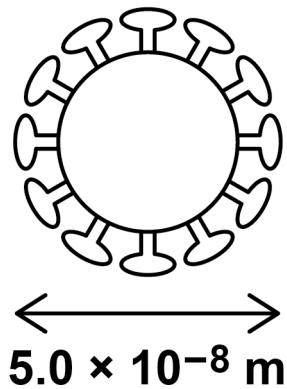
**PLANT CELL**



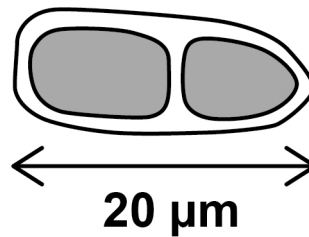
**BACTERIUM**



**VIRUS**



**FUNGAL SPORE**



**0 4 . 5** Calculate how many times longer the plant cell is than the bacterium. [3 marks]

---

---

---

---

---

---

---

---

---

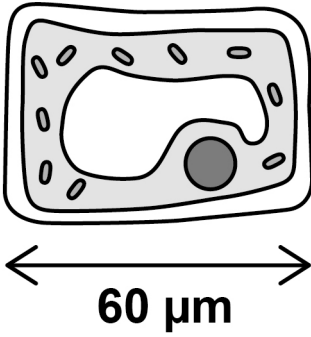
**Number of times longer =** \_\_\_\_\_

**[Turn over]**

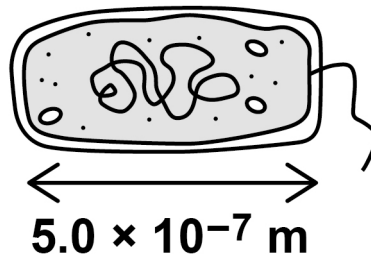


Repeat of FIGURE 3

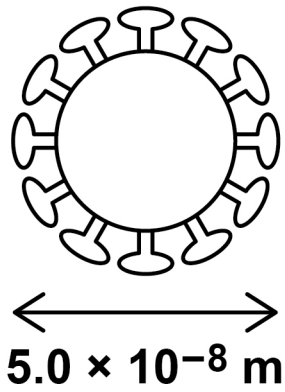
PLANT CELL



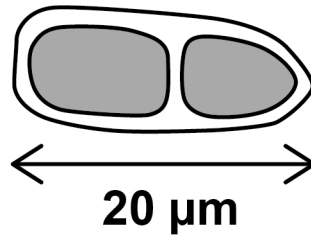
BACTERIUM



VIRUS



FUNGAL SPORE



**0 4 . 6** In the school laboratory, a student could observe a fungal spore but **NOT** a virus.

**Give a reason why.**

**Use information from FIGURE 3. [1 mark]**

---

---

---

---

**[Turn over]**

**04.7** Scientists investigated the effect of sulfur dioxide concentration in the air on the number of infections in rose bushes.

- The rose bushes were grown for 1 year in greenhouses.
- The greenhouses had different concentrations of sulfur dioxide in the air.
- The rose bushes had no infections at the beginning of the year.
- All other conditions were kept the same.

**TABLE 5** shows the results.

**TABLE 5**

| <b>Concentration of sulfur dioxide in the air in <math>\mu\text{g}/\text{m}^3</math></b> | <b>Percentage of rose bushes with infections after 1 year</b> |
|--|---|
| <b>0</b>   | <b>75</b>   |
| <b>20</b>  | <b>73</b>   |
| <b>40</b>  | <b>28</b>   |
| <b>60</b>  | <b>9</b>  |
| <b>80</b>  | <b>4</b>  |
| <b>100</b>   | <b>0</b>  |
| <b>120</b>   | <b>0</b>  |



The Clean Air Act of 1956 was introduced to reduce air pollution.

After 1956, gardeners reported an increased number of infections in rose bushes.

Explain why.

Use data from TABLE 5. [3 marks]

---

---

---

---

---

---

---

---

---

---

---

---

---

[Turn over]

|    |
|----|
|    |
| 18 |

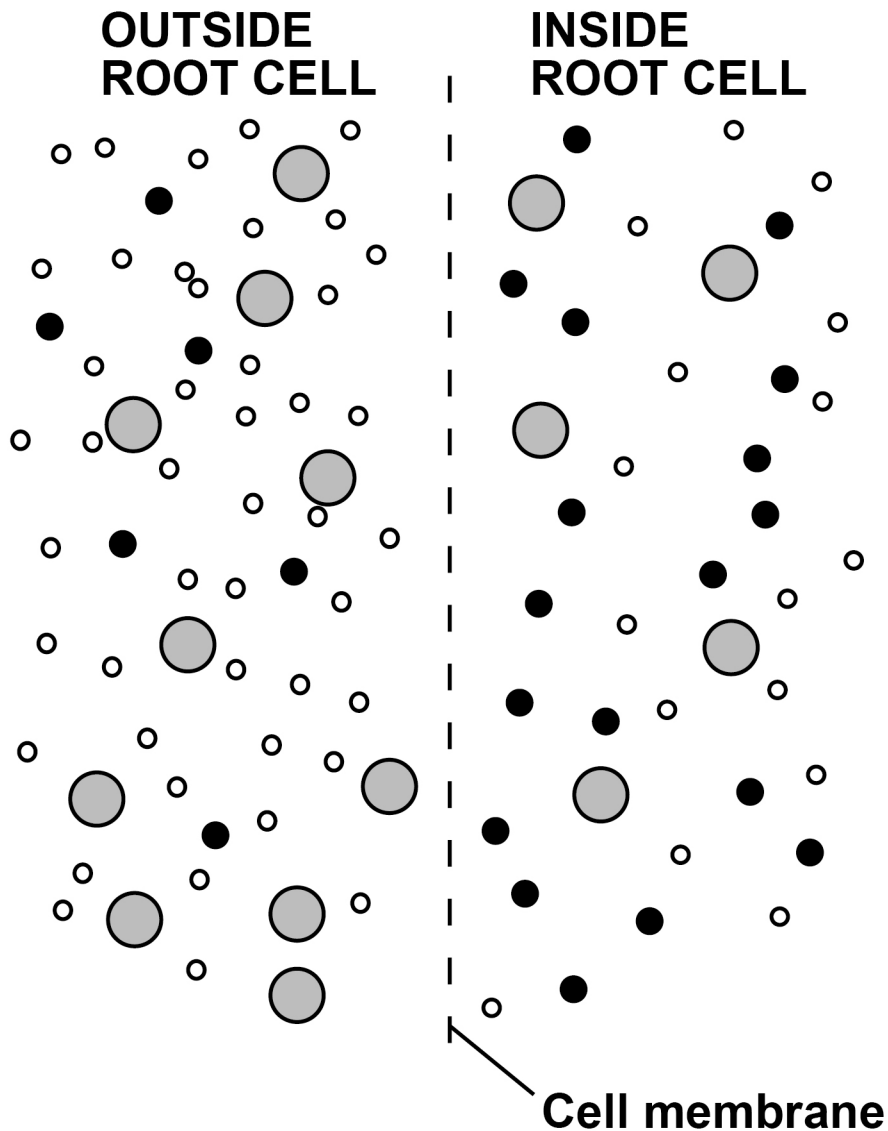


05

Substances are transported across cell membranes by different processes.

FIGURE 4 represents a section of cell membrane in a plant root.

FIGURE 4



**KEY**

- Substance A
- Substance B
- Substance C





**0 5 . 1** Substance B moves into the root cell.

**Suggest what substance B is.**

**Explain your answer. [3 marks]**

---

---

---

---

---

---

---

---

---

---

---

---

---

**[Turn over]**

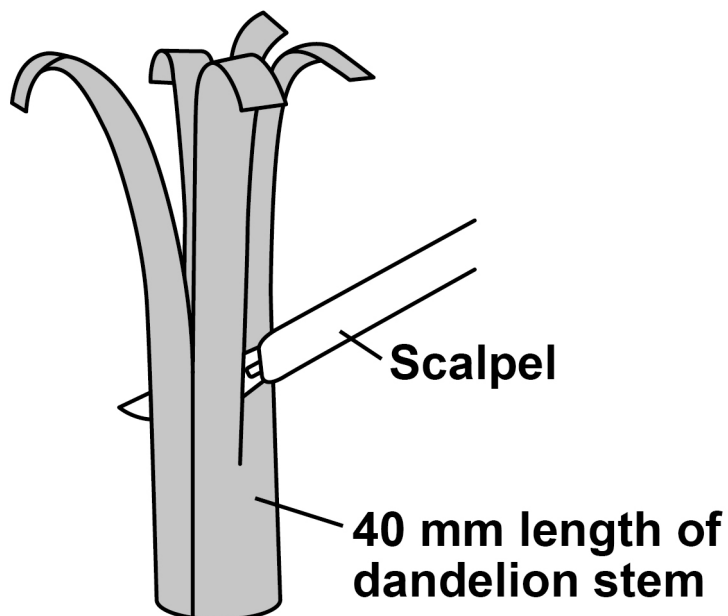
Students wanted to determine the concentration of sugar solution in dandelion cells.

This is the method used.

1. Cut a 40 mm length of dandelion stem into five identical strips.
2. Draw the appearance of a strip.
3. Place each strip into a different concentration of sugar solution.
4. After 1 hour, draw the appearance of each strip.

FIGURE 5 shows how the dandelion stem was cut.

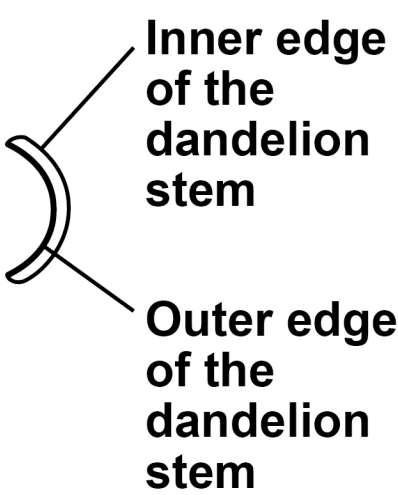





FIGURE 5



The cells on the outer edge of the dandelion strip have a waxy waterproof layer.

TABLE 6 shows the students' drawings of the strips of dandelion stem.

TABLE 6

| Concentration of sugar solution in mol/dm <sup>3</sup> | Appearance of dandelion strip at start   | Appearance of dandelion strip after 1 hour  |
|--|--|---|
| 0.0  |  |    |
| 0.2  |  |  |
| 0.4  |  |  |
| 0.6  |  |  |
| 0.8  |  |  |

[Turn over]



**0****5**.**2**

Explain the result for the 0.2 mol/dm<sup>3</sup> sugar solution. [4 marks]

---

---

---

---

---

---

---

---

---

---

---

---

---

---

---

---

---

---

---

---

---

---

---

---

---

---

---

---

---

---

---



**05.3** Suggest the concentration of sugar solution in the dandelion cells.

Use TABLE 6, on page 43. [1 mark]

Concentration = \_\_\_\_\_ mol/dm<sup>3</sup>

**05.4** Explain your answer to Question 05.3.  
[2 marks]

---

---

---

---

---

---

---

---

---

---

---

**[Turn over]**



**0 5 . 5** The results shown in TABLE 6 are qualitative.

**Qualitative results depend on a person's judgement so may not be accurate.**

**The students wanted to determine the concentration of sugar solution in dandelion cells.**

**Describe how the method could be improved to obtain an accurate, quantitative result.  
[2 marks]**

---

---

---

---

---

---

---

---

---

---

|           |
|-----------|
|           |
| <b>12</b> |



**BLANK PAGE**

**[Turn over]**



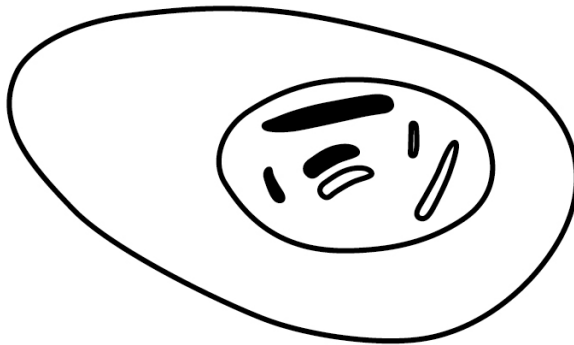
**0 6**

There are two different types of cell division.

The body cells of a mosquito each contain six chromosomes.

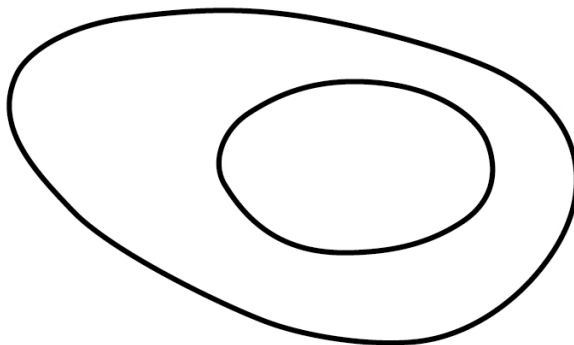
FIGURE 6 shows a body cell of a mosquito.

FIGURE 6

**0 6 . 1**

Complete FIGURE 7 to show the chromosomes in a cell produced by mitosis from the cell in FIGURE 6. [1 mark]

FIGURE 7





**06.2**

**Describe the similarities and differences between mitosis and meiosis. [4 marks]**

---

---

---

---

---

---

---

---

---

---

---

---

---

---

---

---

---

---

---

---

---

---

---

---

---

**[Turn over]**



**Achondroplasia is an inherited condition.**

**People with achondroplasia are often short in height and have short limbs.**

**Achondroplasia is caused by a gene mutation.**

**06.3**

**Describe the difference between a gene and an allele. [1 mark]**

---

---

---

---

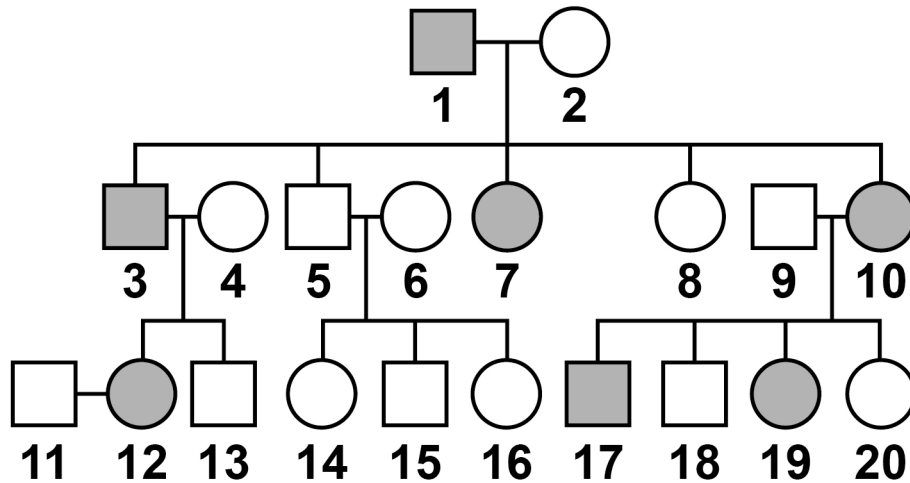
**BLANK PAGE**

**[Turn over]**







**FIGURE 8** shows the inheritance of achondroplasia in one family.

**FIGURE 8**



**KEY**

-  Male with achondroplasia
-  Female with achondroplasia
-  Male without achondroplasia
-  Female without achondroplasia



**Achondroplasia is caused by a dominant allele.**

**0 6 . 4 Define the term 'dominant allele'. [1 mark]**

---

---

---

**0 6 . 5 Look at FIGURE 8.**

**Is person 3 homozygous or heterozygous for achondroplasia?**

**Explain your answer. [1 mark]**

---

---

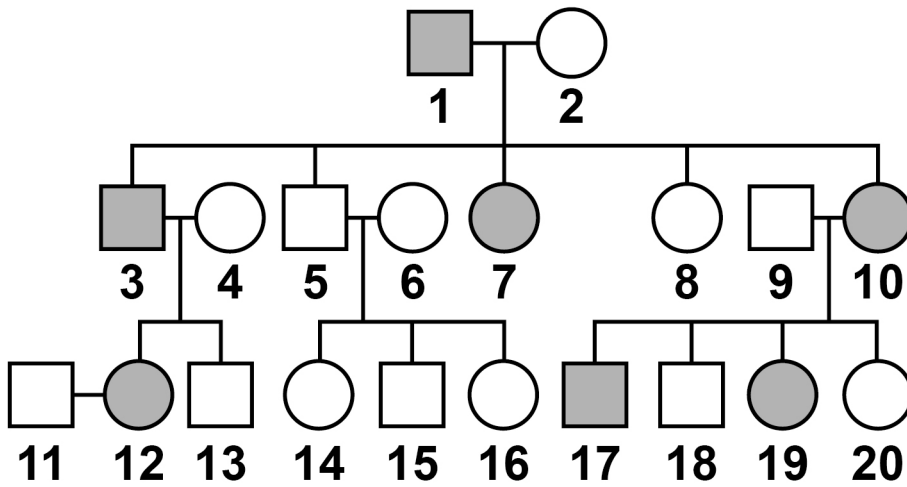
---

---





**[Turn over]**



## Repeat of FIGURE 8



## KEY

-  Male with achondroplasia
-  Female with achondroplasia
-  Male without achondroplasia
-  Female without achondroplasia



**06.6** Complete the Punnett square diagram to show the possible offspring of person 11 and person 12 in FIGURE 8.

Identify which children would:

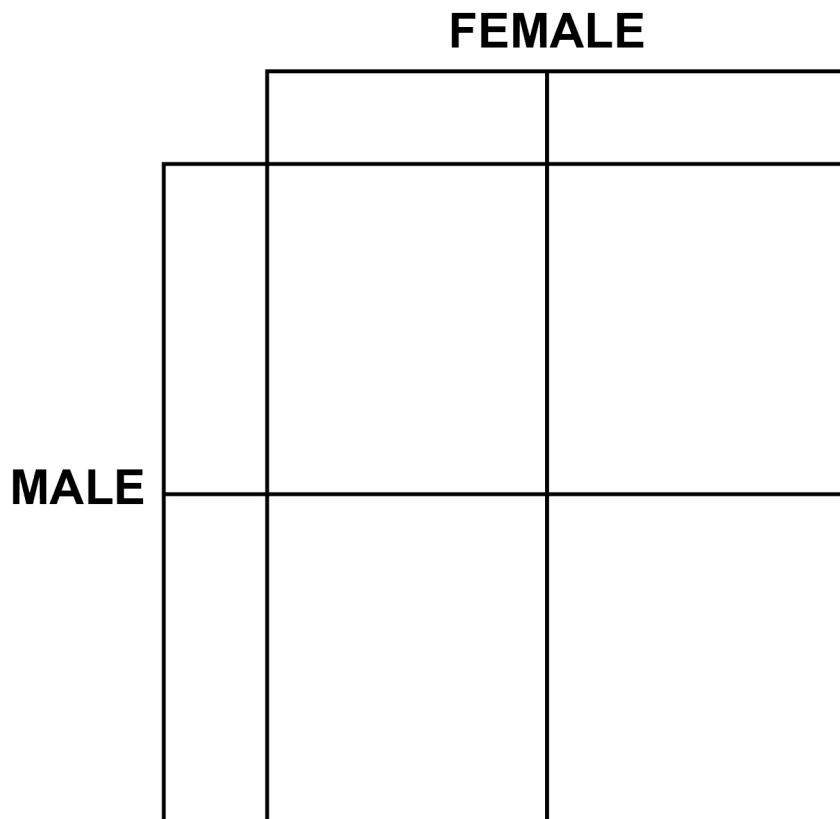
- have achondroplasia
- NOT have achondroplasia.

[4 marks]

Use the symbols:

**A** = dominant allele

**a** = recessive allele



[Turn over]



**0 7** There are different types of electromagnetic wave.

**0 7 . 1** Which type of electromagnetic wave has the shortest wavelength? [1 mark]

---

---

**0 7 . 2** A new technology has been developed to charge small electrical devices from the radio waves in the air around us.

**Explain how radio waves could charge a small electrical device. [2 marks]**

---

---

---

---

---

---

---

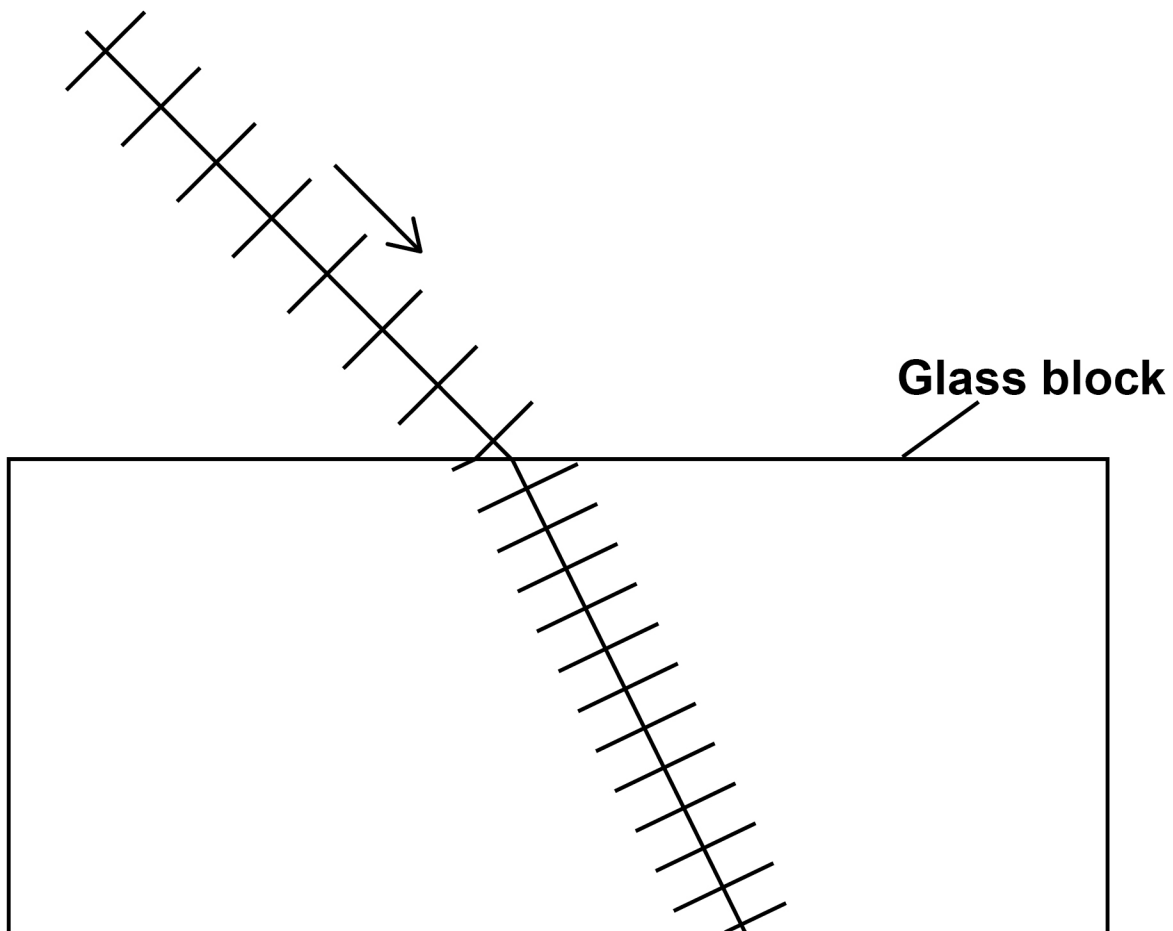




**FIGURE 9** shows the wavefronts of a light wave passing through air into a glass block.

**07.3** Complete **FIGURE 9** to show the wavefronts as they pass out into the air. [2 marks]

**FIGURE 9**



**[Turn over]**



**07.4** Explain why there is refraction at the boundary between air and glass. [3 marks]

---

---

---

---

---

---

---

---

---

---

---

---

---

---

---

---

---



**0 7 . 5** The period of a wave in a ripple tank was measured.

The period of the wave was 420 ms

The speed of the wave was 0.60 m/s

Calculate the wavelength of the wave.  
**[5 marks]**

---

---

---

---

---

---

---

---

---

---

---

---

---

---

---

---

---

---

---

---

---

---

---

---

**Wavelength = \_\_\_\_\_ m**

**[Turn over]**

|           |
|-----------|
|           |
| <b>13</b> |



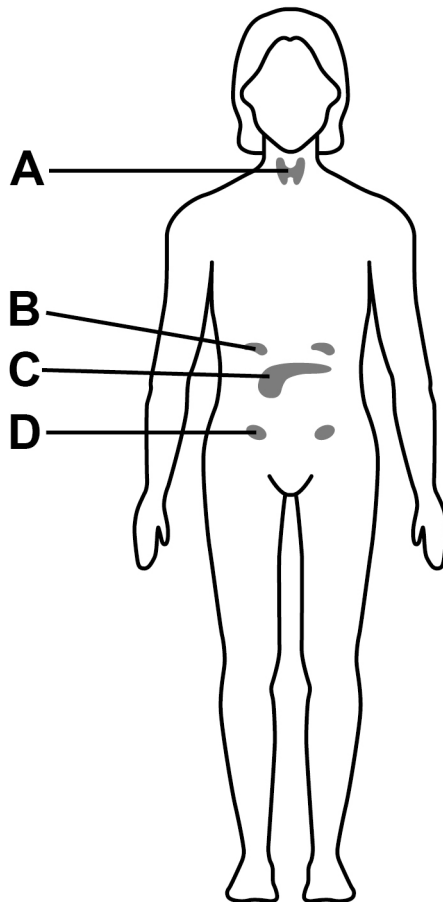
08

Hormones control many processes in the body.

Hormones are released from glands.

**FIGURE 10** shows the position of some glands in the female body.

**FIGURE 10**



**0 8 . 1** Which gland controls blood glucose concentration? [1 mark]

Tick (✓) **ONE** box.

**A**

**B**

**C**

**D**

**[Turn over]**



**0 8 . 2** Some foods can cause blood glucose concentration to increase.

**Explain how the body responds to an increase in blood glucose concentration. [3 marks]**

---

---

---

---

---

---

---

---

---

---

---

---

---

---

---

---

---

---

---

---

---

---

---



**People with diabetes find it difficult to control their blood glucose concentration.**

**Research has shown that glucagon-blocking drugs may help people with Type 1 diabetes.**

**0 8 . 3 Explain how a person with Type 1 diabetes might change their treatment if they were taking glucagon-blocking drugs. [2 marks]**

---

---

---

---

---

---

---

**[Turn over]**



**08.4** Some pregnant women develop gestational diabetes (GDM).

**GDM can cause high blood glucose concentrations in pregnant women.**

**Scientists collected data to see if GDM in pregnant women affected the mass of their children.**

**The scientists recorded the mass of each child:**

- **at birth**
- **when they were a teenager.**

**The BMI of each mother was recorded.**

**BMI is a measure of whether a person has a healthy mass for their height.**





**TABLE 7 shows some of the information from this very large study.**

**TABLE 7**

|                                     |                     | <b>Mean BMI of mothers</b> | <b>Mean mass at birth of children in kg</b> | <b>Percentage of the children who were overweight as teenagers</b> |
|-------------------------------------|---------------------|----------------------------|---|--|
| <b>Mothers who had GDM</b>          | <b>Female child</b> | <b>27.2</b>                | <b>3.55</b>                                 | <b>6.5</b>   |
|                                     | <b>Male child</b>   | <b>26.8</b>                | <b>3.68</b>                                 | <b>13.2</b>  |
| <b>Mothers who did not have GDM</b> | <b>Female child</b> | <b>25.0</b>                | <b>3.44</b>                                 | <b>4.9</b>   |
|                                     | <b>Male child</b>   | <b>24.9</b>                | <b>3.58</b>                                 | <b>8.7</b>   |

**[Turn over]**



**BLANK PAGE**



**Give THREE possible conclusions about the incidence and effect of GDM.**

**Use information from TABLE 7, on page 65. [3 marks]**

**1**

---

**2**

---

**3**

---

|          |
|----------|
|          |
| <b>9</b> |

**END OF QUESTIONS**



**BLANK PAGE**

| For Examiner's Use |      |
|--------------------|------|
| Question           | Mark |
| 1                  |      |
| 2                  |      |
| 3                  |      |
| 4                  |      |
| 5                  |      |
| 6                  |      |
| 7                  |      |
| 8                  |      |
| <b>TOTAL</b>       |      |

**Copyright information**

For confidentiality purposes, from the November 2015 examination series, acknowledgements of third-party copyright material are published in a separate booklet rather than including them on the examination paper or support materials. This booklet is published after each examination series and is available for free download from [www.aqa.org.uk](http://www.aqa.org.uk) after the live examination series.

Permission to reproduce all copyright material has been applied for. In some cases, efforts to contact copyright-holders may have been unsuccessful and AQA will be happy to rectify any omissions of acknowledgements. If you have any queries please contact the Copyright Team, AQA, Stag Hill House, Guildford, GU2 7XJ.

Copyright © 2019 AQA and its licensors. All rights reserved.

**IB/M/MW/Jun19/8465/2H/E4**

6 8



1 9 6 G 8 4 6 5 / 2 H